

APPLICATION OF CFD FOR TURBULENCE RELATED OPERATIONAL RISKS ASSESSMENT OF WIND TURBINES IN COMPLEX TERRAIN

RESOURCE ASSESSMENT PART 1

2013·2·5

Contributors



Tsubasa Windfarm Design, Tokyo, Japan
Graham Li – Founder and Chief Architect



Eurus Energy Holdings, Tokyo, Japan
Susumu Takakuwa – Wind Risk Manager



Research Institute for Applied Mechanics,
Kyushu University, Japan
Associate Professor Dr Takanori Uchida
Developer of CFD Software RIAM-COMPACT

Case

Turbine T7 registered a particular high frequency of yaw related failures

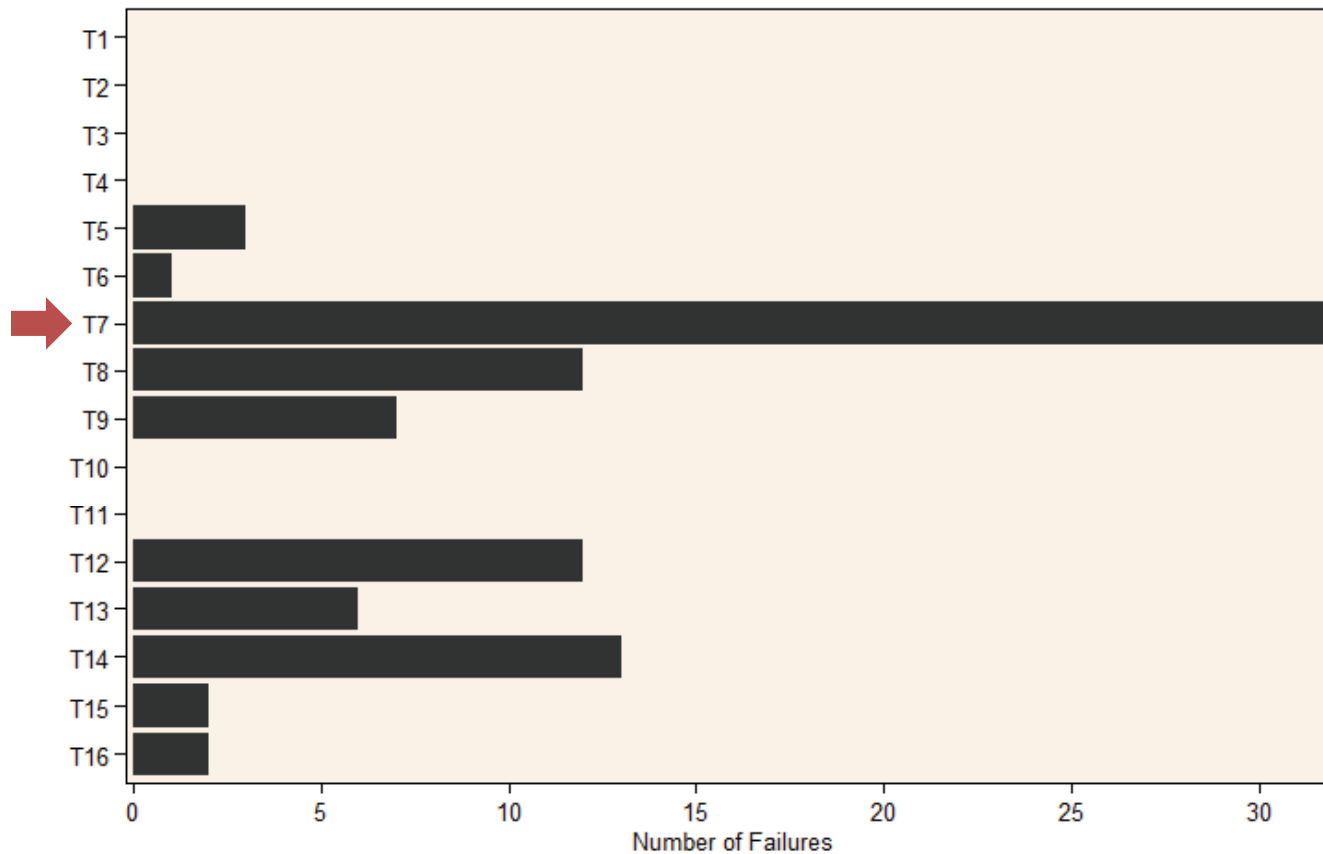

7 years since the start of operation

Damages

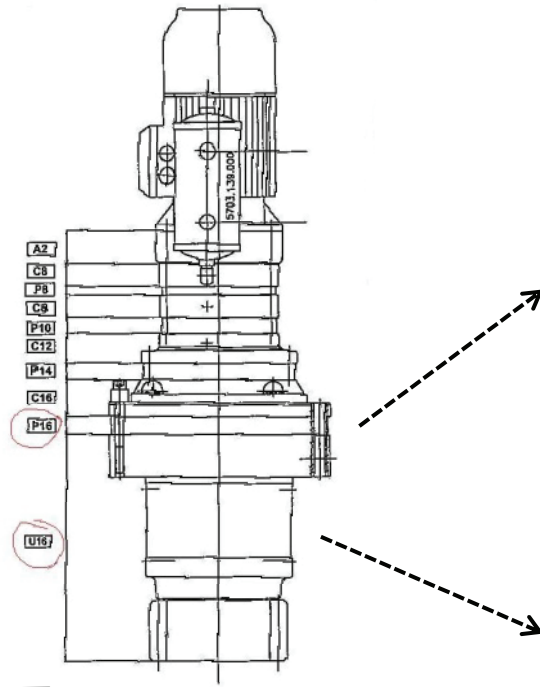

Yaw Motor ▪ Yaw Gear

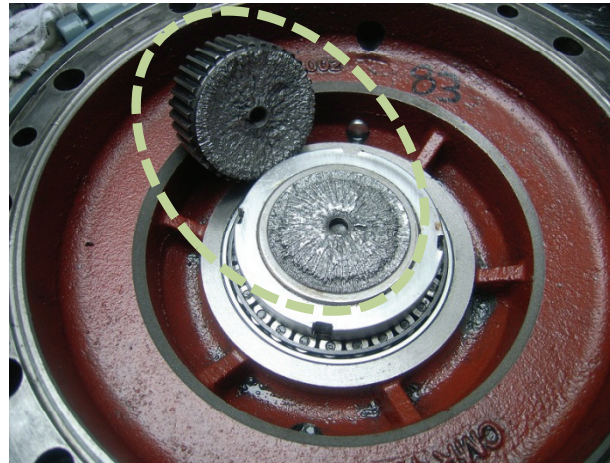

Broken Shaft

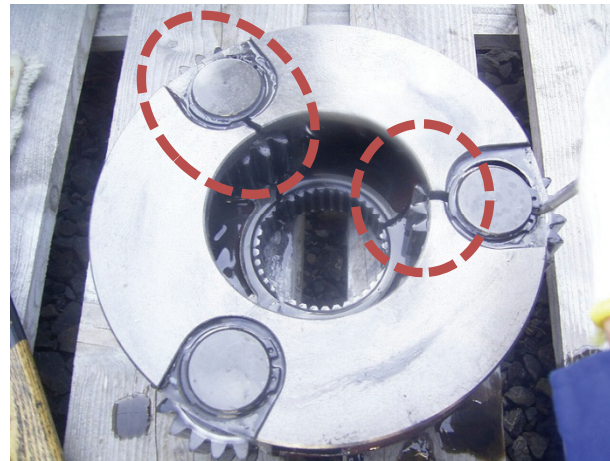

Cracks

Windfarm



Siemens SWT1.3-62 x 16
Hub Height 60m
Rotor Diameter 62m
IEC Class 1A
Operation since February 2004

Kihoku Windfarm
Kagoshima Prefecture, Kyushu, Japan

Approach

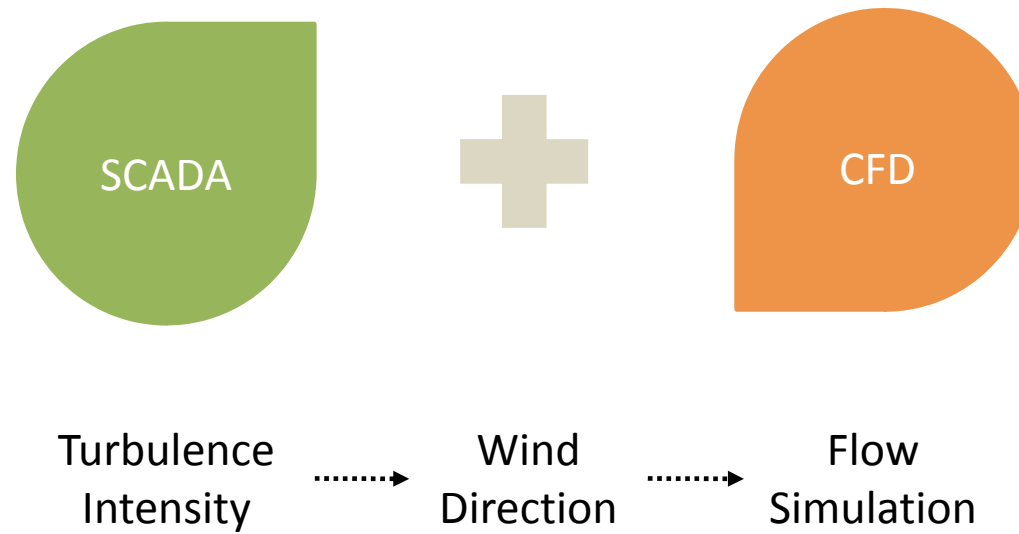

SCADA ▪ $T_{I_{Raw}}$ minus $T_{I_{IEC}}$

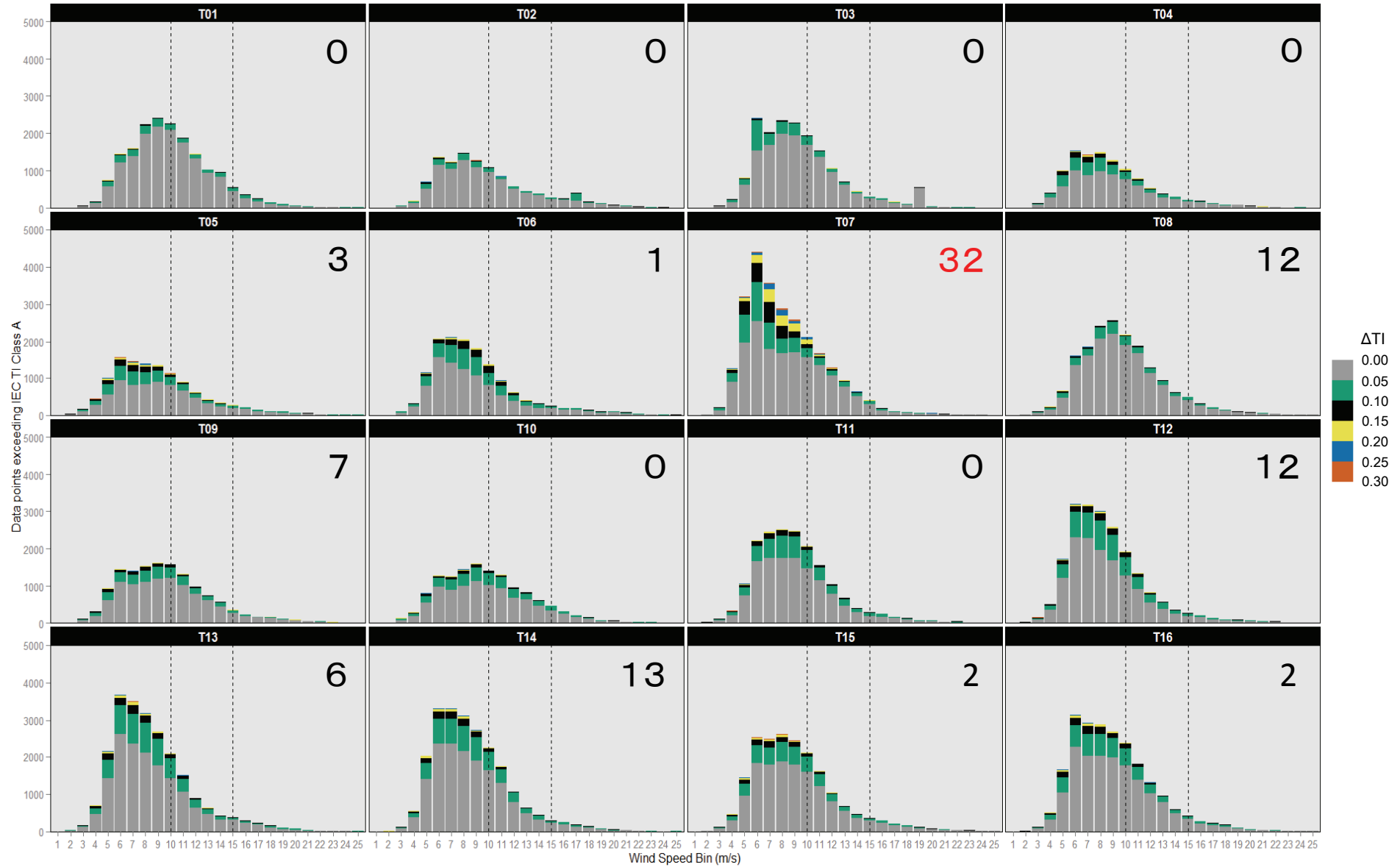

SCADA ▪ T7 ▪ Rose

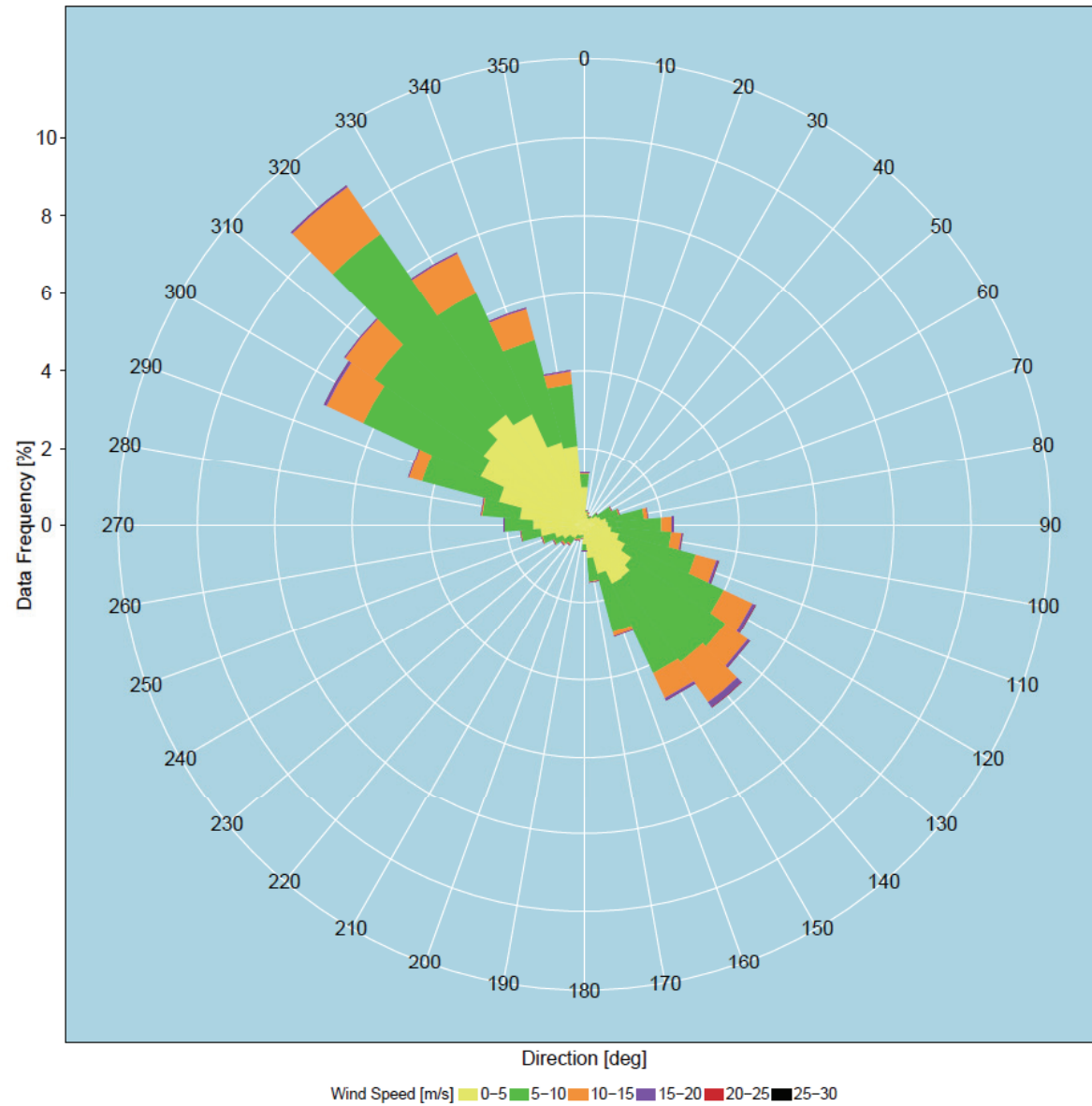

SCADA ▪ T7 ▪ TI

Yellow Line - measured data (characteristic TI)
Red Line - IEC Class A Standard (2nd Edition)

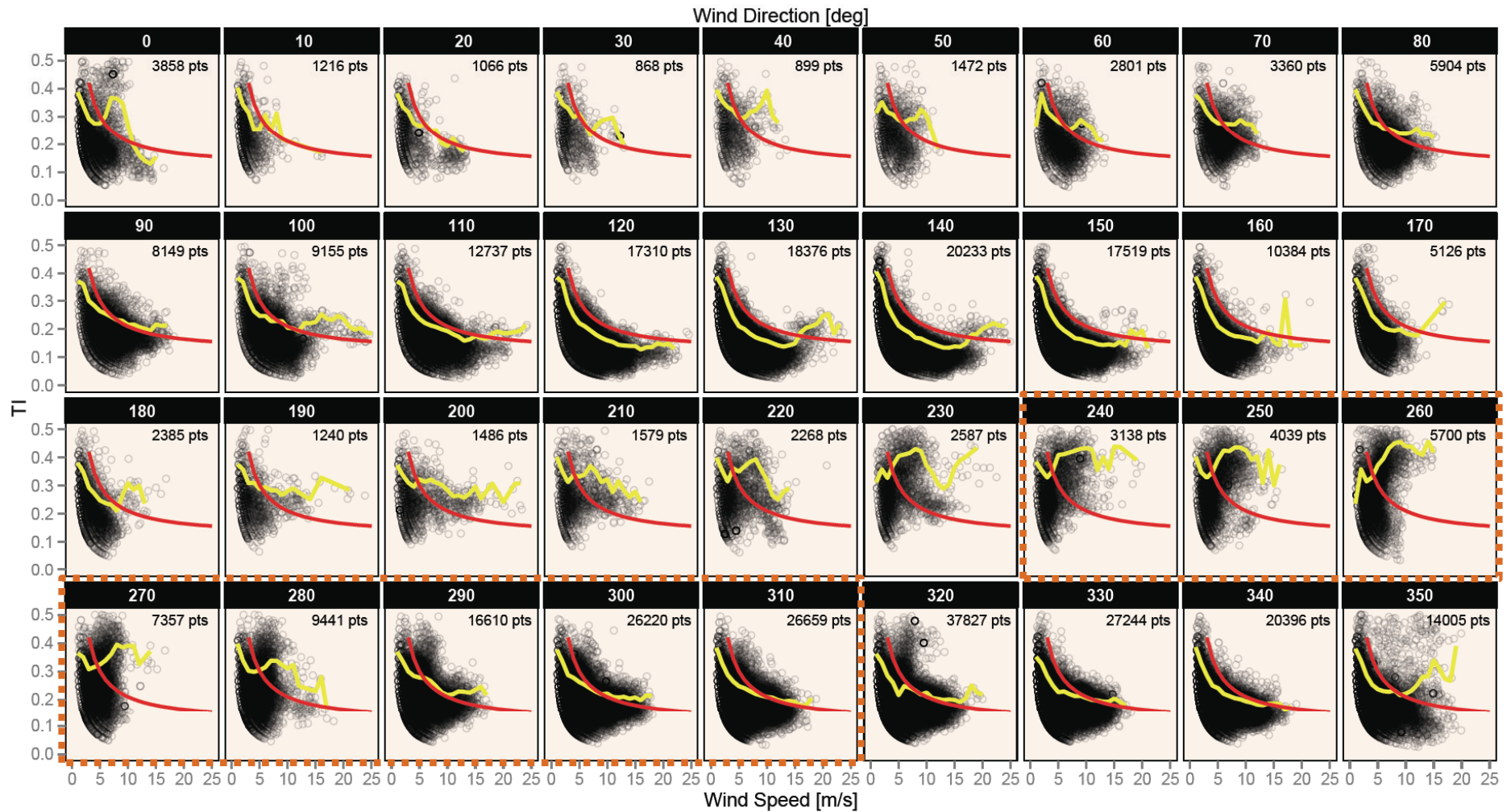

SCADA ▪ T7 ▪ Topography ▪ TI

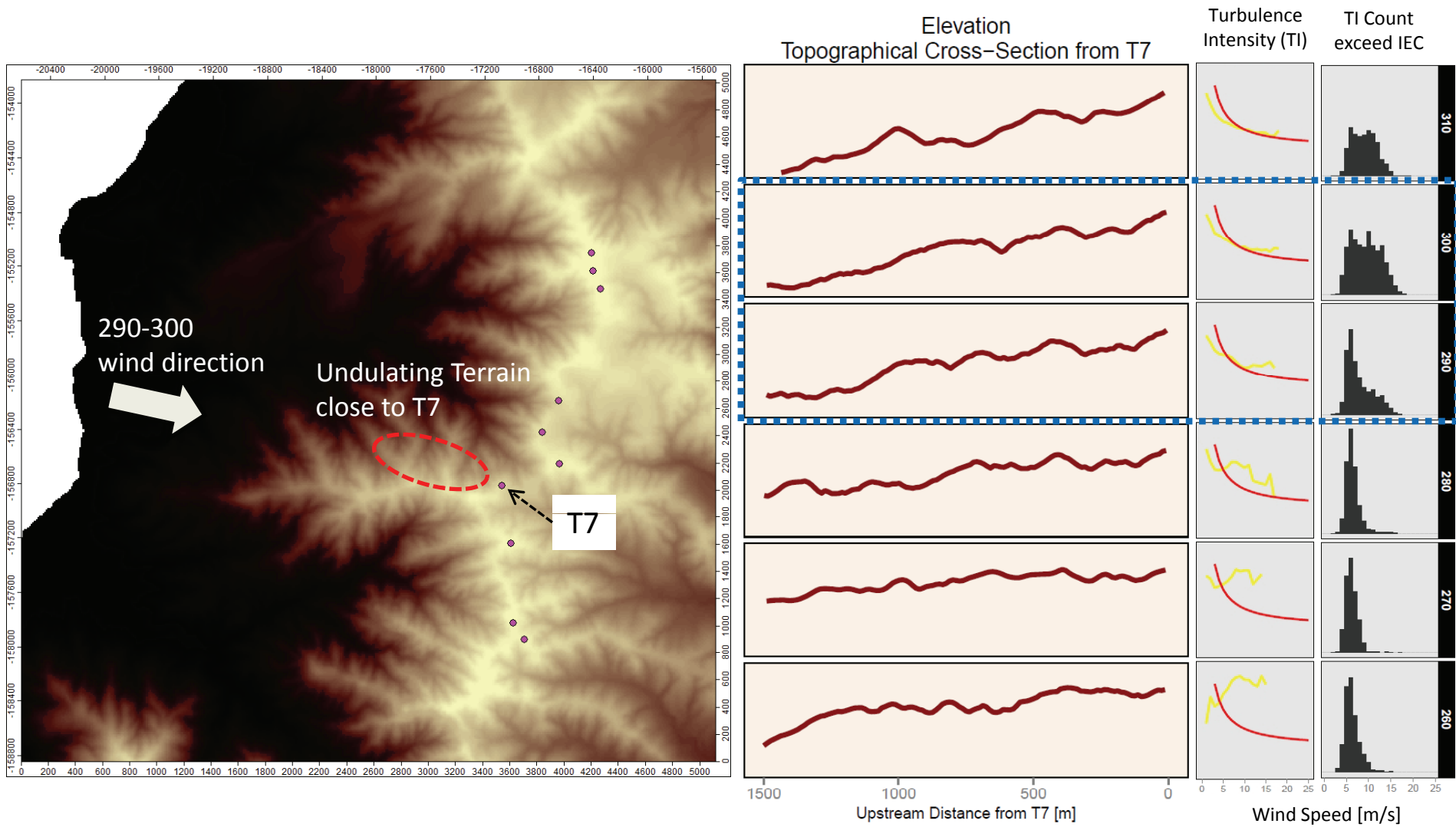

Topography

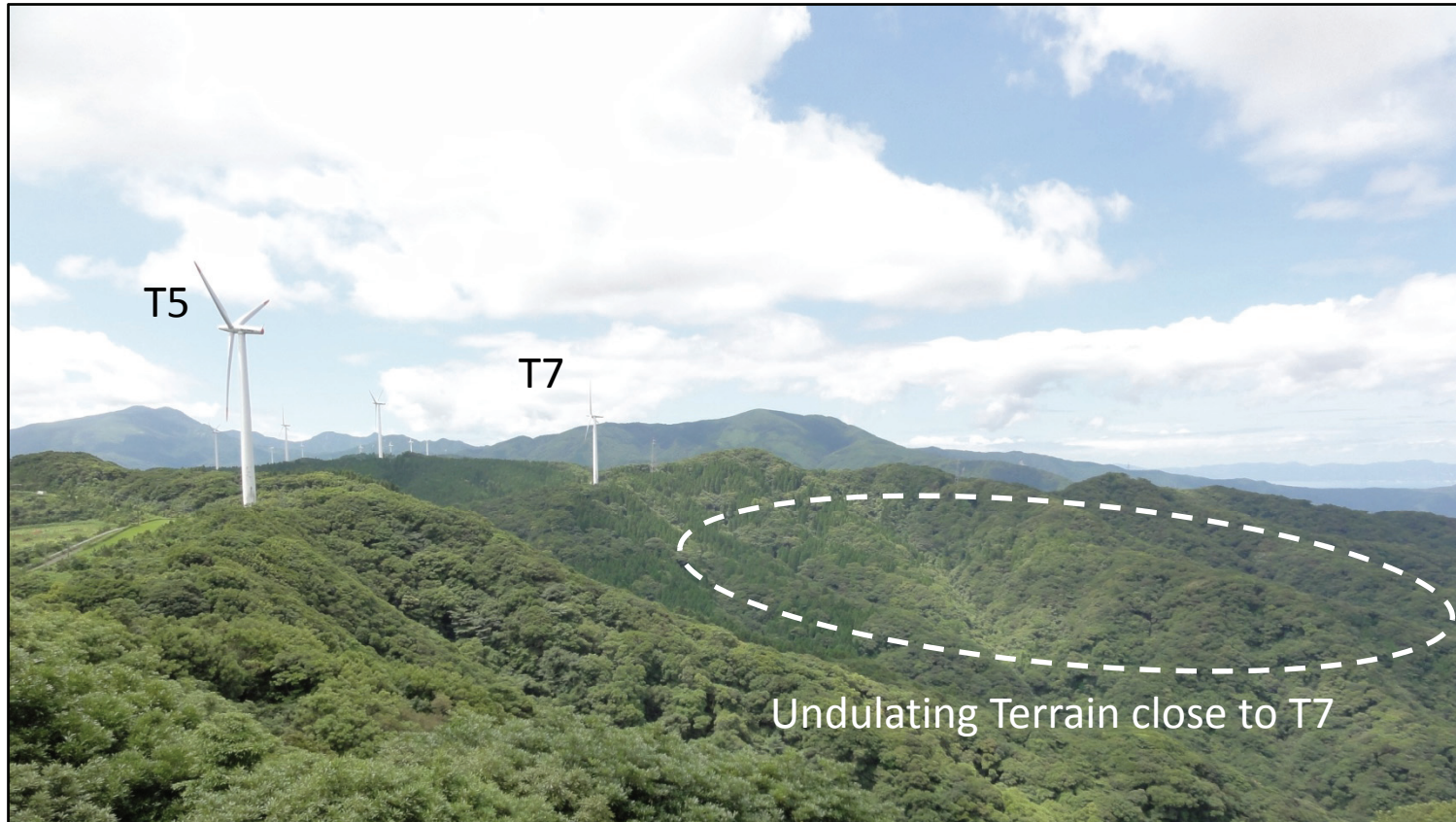

CFD ▪ Model

Software

RIAM-COMPACT

Turbulence Model

LES Smagorinsky

Calculation Area (km)

$5.6(x) \times 6.3(y) \times 3.1(z)$

Mesh Size

x : 10m ~ 50m

y : 10m

z : 1m (minimum)

Mesh Grid

$401(x) \times 631(y) \times 61(z)$

Total Grid Points

15,430,000

Inflow Wind Direction

290 degree

Inflow Wind Speed

7m/s

Inflow Shear Exponent

0.14

Atmospheric Stability

Neutral

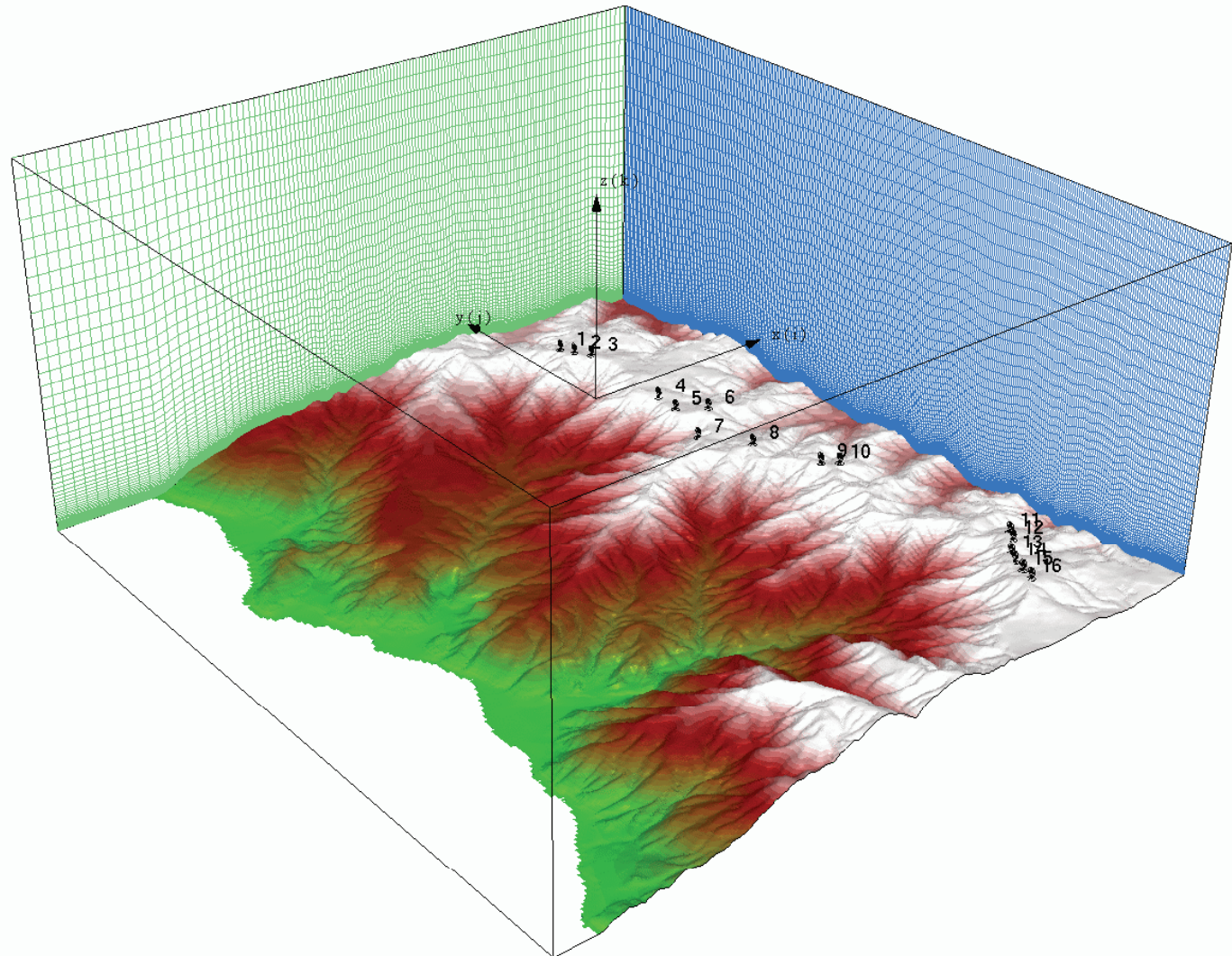

CFD ▪ Vector

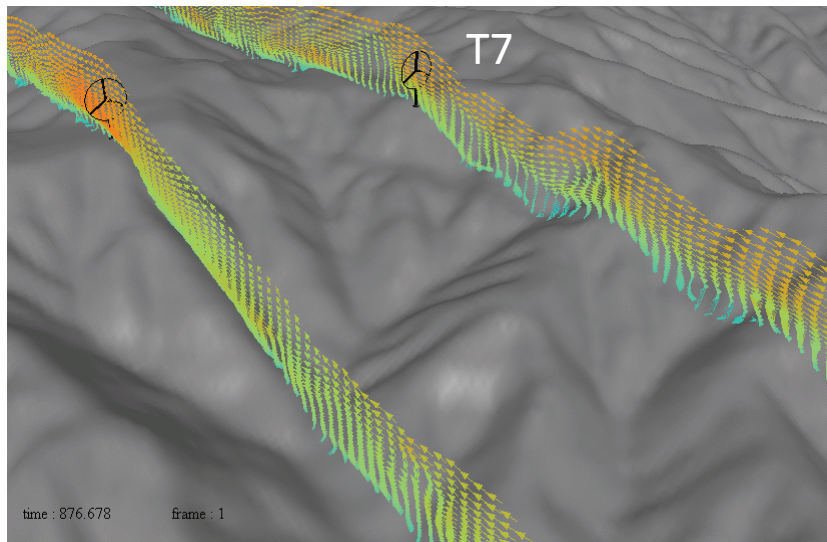

Flow Separation upstream of T7

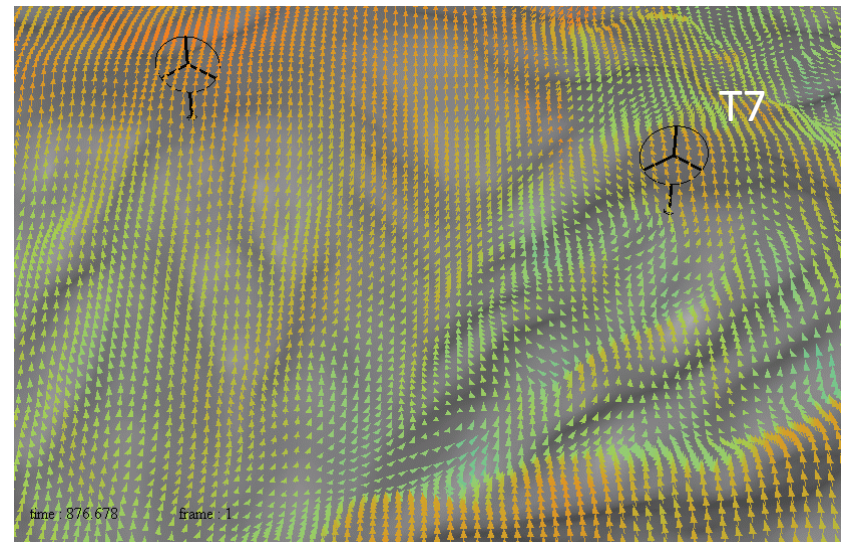

Wind Direction Fluctuation at T7

CFD ▪ Shading

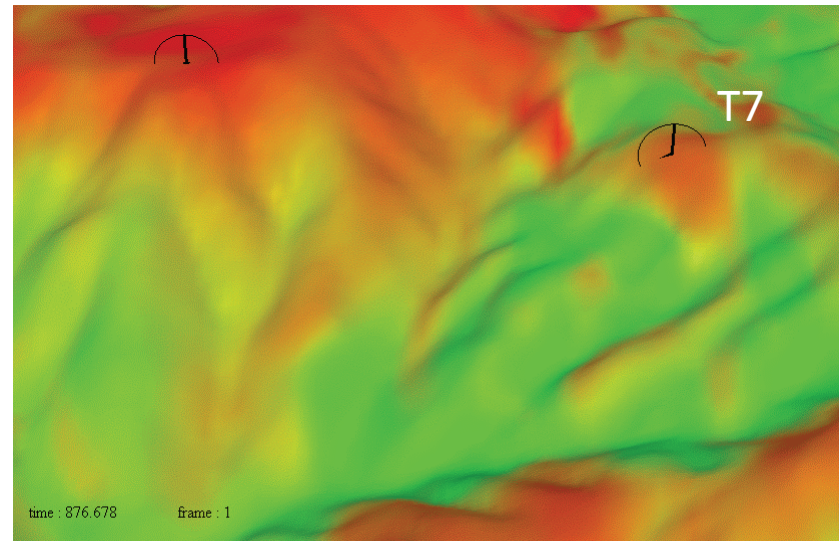
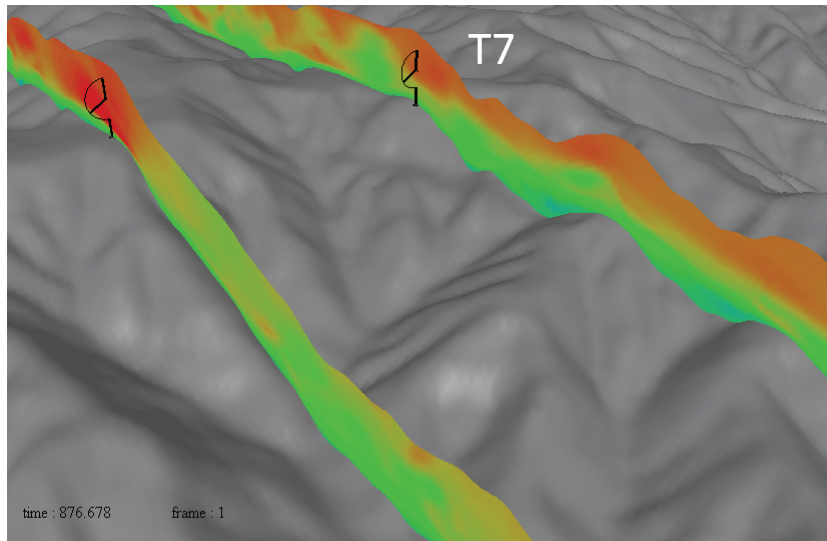

Large and Fluctuating Wind Speed Difference
across Rotor Face of T7

CFD ▪ Time Series

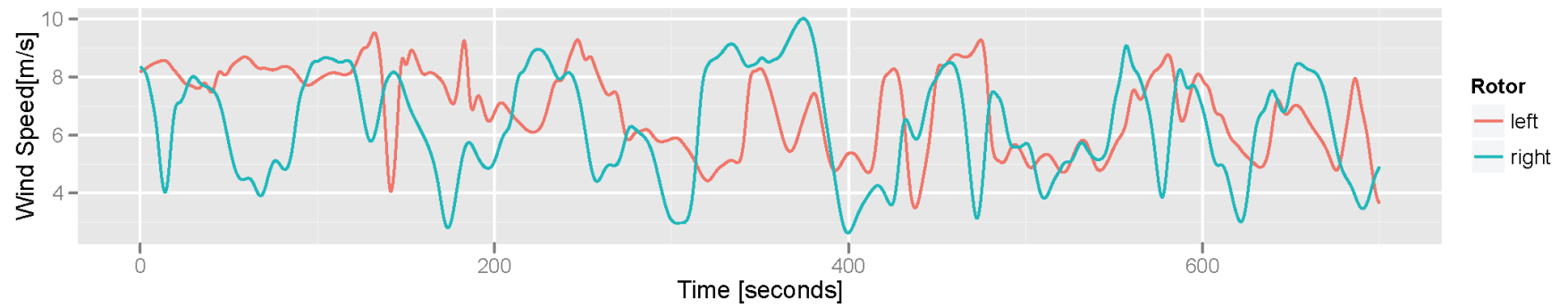
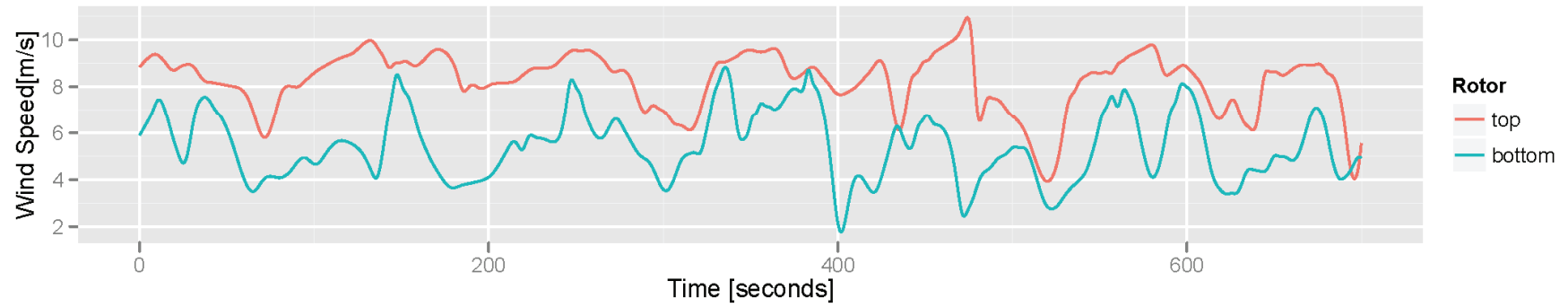

CFD ▪ Time Series

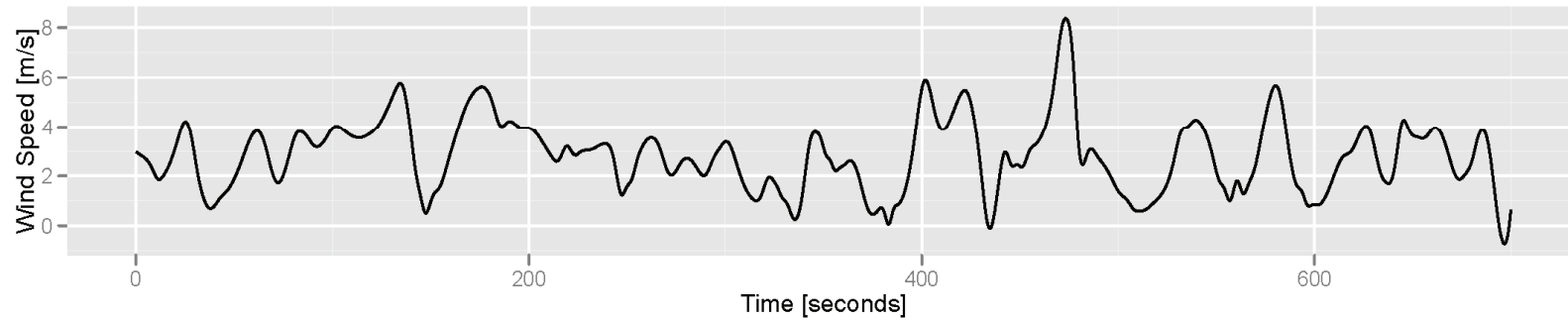

Top
Minus
Bottom

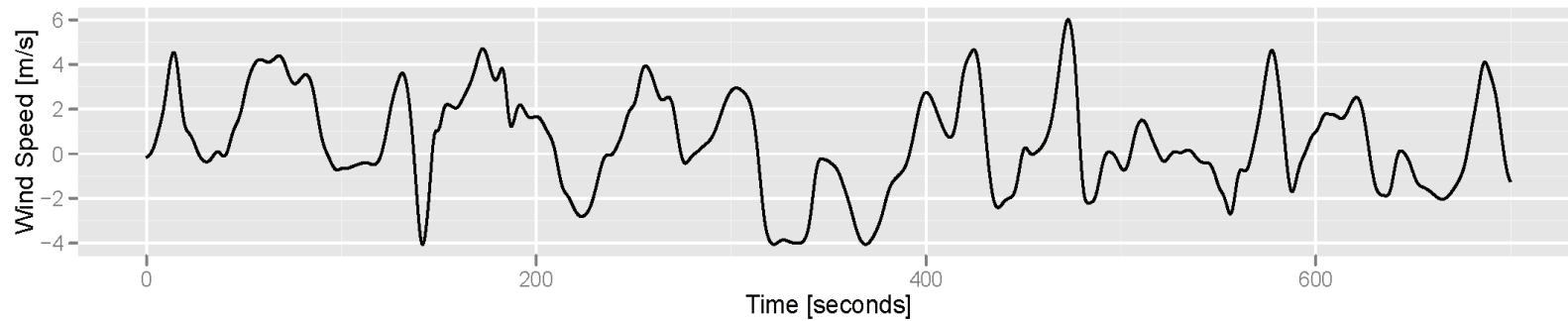

Left
Minus
Right

Summary

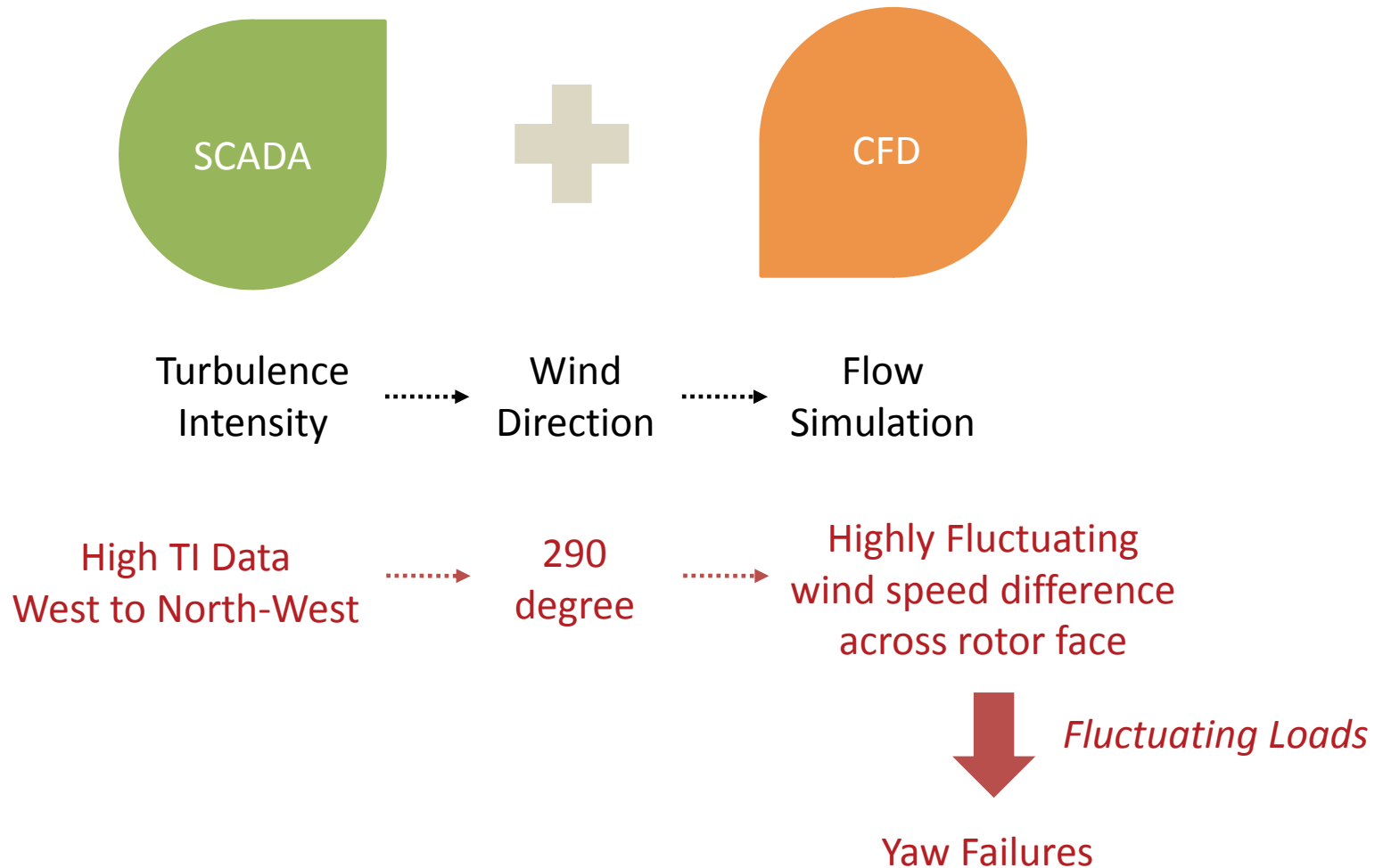

Implications ▪ Future

- ❑ The same approach has been applied to other existing wind farms with satisfactory results.
- ❑ The temporal and spatial wind speed distribution provides useful information about turbulent wind conditions and can be used as inputs for load calculation.
- ❑ LES-based CFD simulation thus has the potential for assessing the operational risk associated with turbulent wind conditions for both existing operational wind farms and new wind farms under planning.

Thank you for Listening !